

# STAND UP bed motorized

Cod. PEPLIV06385-XXX

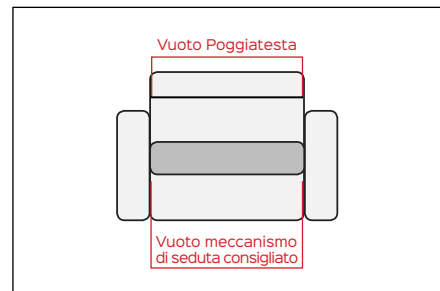

DESIGN IN MOVIMENTO



Vuoto standard (mm)	
Vuoto Meccanismo di seduta consigliato	Vuoto Poggiatesta
540	<b>370</b>
650	<b>480</b>
730	<b>560</b>
800	<b>630</b>
880	<b>710</b>

Oltre 30 misure disponibili

Elettrico	3kg+/-1kg	153°-210°	Poltrone	Divani	Portata:15kg	Cicli:30.000	2 ANNI Meccanismo 2 ANNI Attuatore Garanzia
-----------	-----------	-----------	----------	--------	--------------	--------------	---

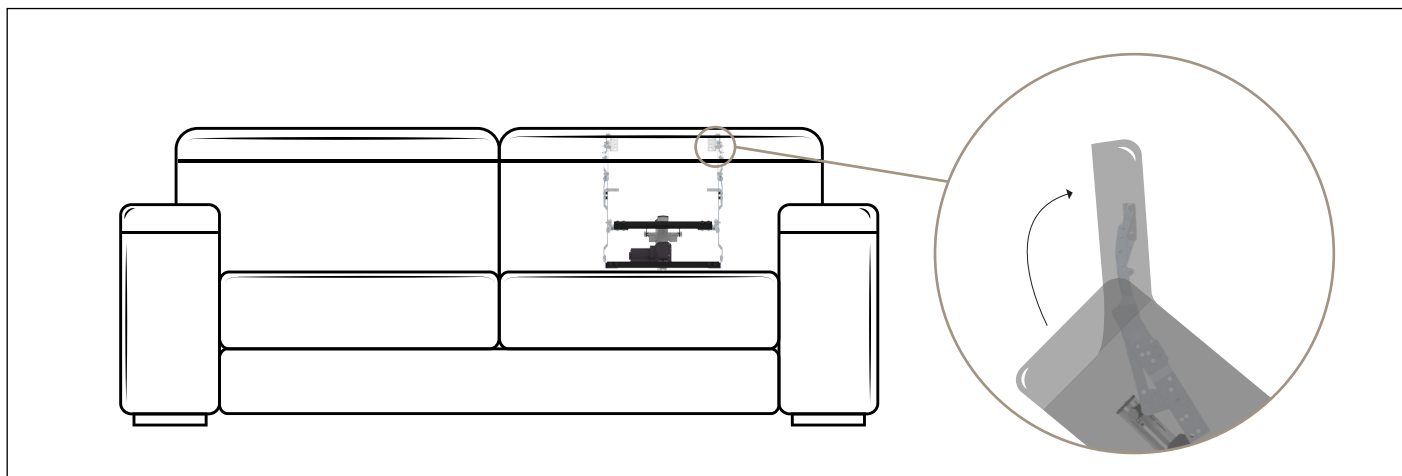

**Benefit:** Il poggiatesta elettrico è completamente foderato all'interno del divano, la struttura estremamente compatta ha le seguenti caratteristiche: rotazione 57°, alzata 54 mm, traslazione 105mm. L'alta qualità dei

materiali e delle componenti elettriche utilizzate rendono questa meccanica efficiente e duratura. STAND UP bed motorized, è stato progettato per essere utilizzato all'interno di schienali fissi, non reclinabili (Divano/letto).

## Optional

KIT ELETTRICI	ATTUATORI
SPINE E PROLUNGHE	ALIMENTATORI E BATTERIE

SISTEMI DI CONTROLLO	INCASSO	PIASTRE
TOUCH SENSOR	TELECOMANDI	CONTROLLO IPAD/IPOD

**Motionitalia Design and quality Made in Italy**

Headquarters: via Navicella 26, 47122 Forlì (FC) Tel.+39 0543 77 47 68 Fax.+39 0543 79 84 09 [www.motionitalia.com](http://www.motionitalia.com) [info@motionitalia.com](mailto:info@motionitalia.com)

Il produttore si riserva il diritto di modificare, in qualsiasi momento e senza preavviso, le specifiche tecniche dei propri prodotti

# STAND UP bed motorized

Code PEPLIV06385-XXX



DESIGN IN MOVIMENTO



Headrest size

Suggested size for the Seat

Standard sizes (mm)	
Suggested size for the Seat	Headrest size
540	<b>370</b>
650	<b>480</b>
730	<b>560</b>
800	<b>630</b>
880	<b>710</b>

More than 30 measures available

Motorized	3kg +/-1kg	153°-210°	Armchairs	Sofas	Load:15kg	Cycles:30.000	2YEARS Mechanism 2YEARS Actuator Warranty
-----------	------------	-----------	-----------	-------	-----------	---------------	---

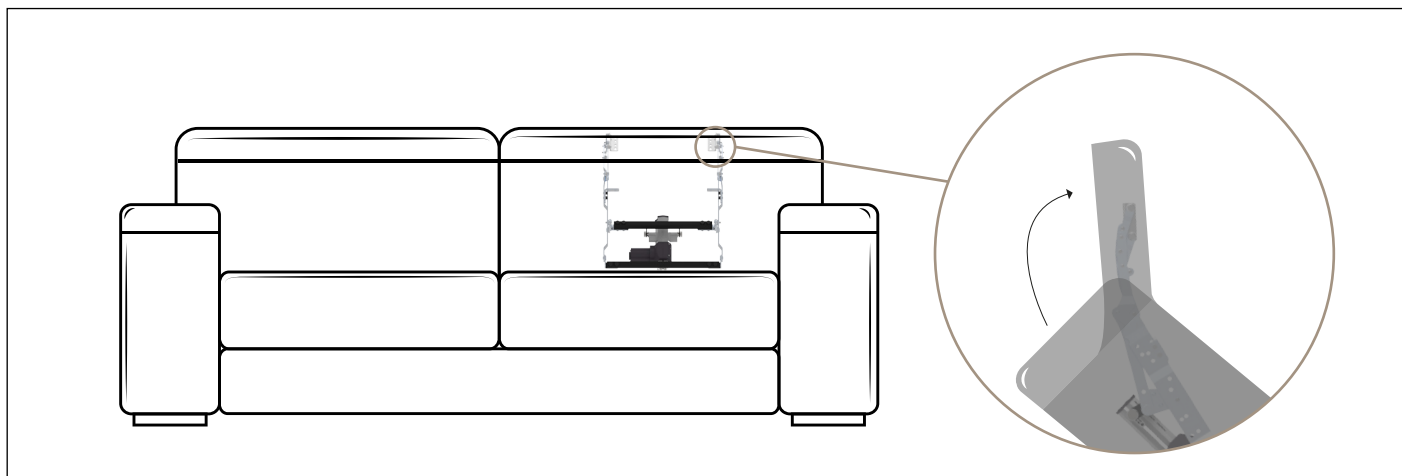

**Benefit:** This motorized headrest is fully upholstered inside the sofa. The very slim structure has the following features: 57° rotation, 54mm shift and 105mm translation. High quality materials and electric kit make this mechanism

highly efficient and long-lasting. STAND UP bed motorized, it is designed to be used inside of fixed, non-reclining backrests (Sofa bed).

## Optional

ELECTRIC KIT	ACTUATORS
PLUGS & CABLE EXTENSIONS	POWER SUPPLY & BATTERY PACKS

CONTROL SYSTEM	BUILT IN SWITCHES	CONTROL PLATES
TOUCH SENSOR	REMOTES	IPAD/IPOD CONTROL SYSTEM

**Motionitalia Design and quality Made in Italy**

Headquarters: via Navicella 26, 47122 Forlì (FC) Tel.+39 0543 77 47 68 Fax.+39 0543 79 84 09 [www.motionitalia.com](http://www.motionitalia.com) [info@motionitalia.com](mailto:info@motionitalia.com)

The producer reserves the right to modify, at any moment and without notice, the technical specification of its products