

SLIDING SITTING *manual*

Code MOCLMA08034-XXX

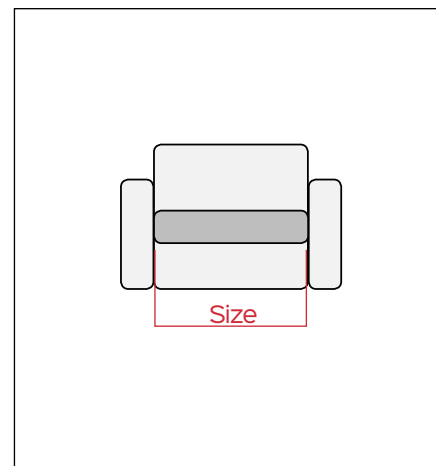

DESIGN IN MOVIMENTO

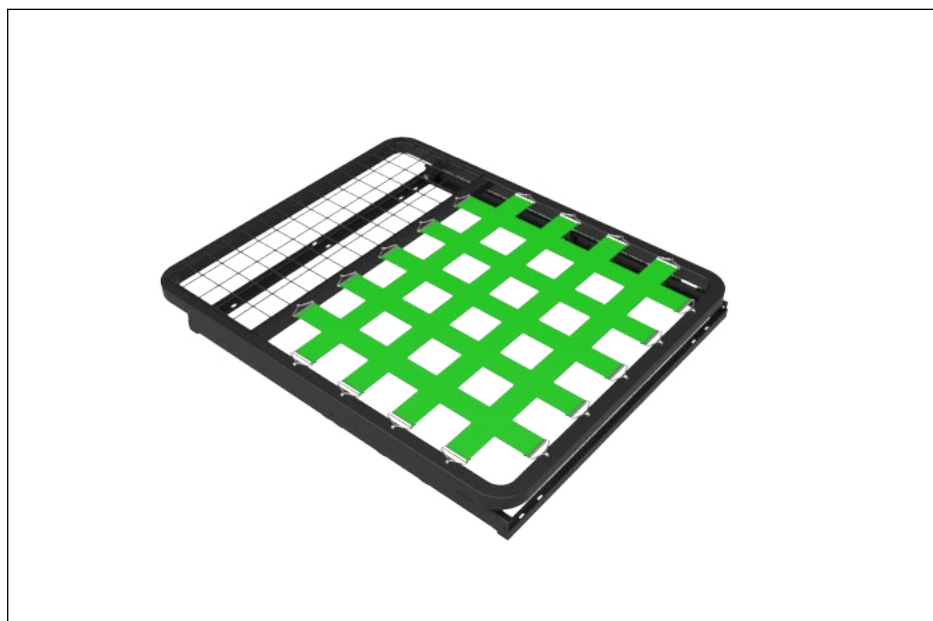

Standard sizes
450
550
650
750

Manual	12,5kg +/- 1kg	0-Wall	Armchairs	Sofas	Load: 100Kg	Cycles: 50.000	2YEARS Warranty
--------	----------------	--------	-----------	-------	-------------	----------------	-----------------

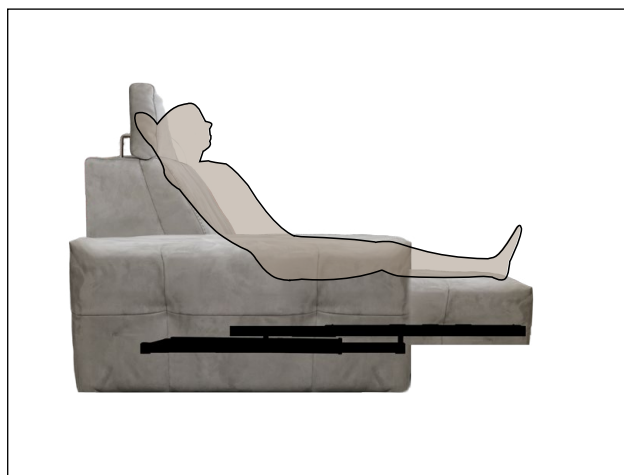

Positions:



Closed



Full Relax

Benefit: The sliding sitting mechanism manual is simple that fits to the frame of the sofa, it's made to high quality material to avoid wear over time. The structure of the mechanism is light but functional, easy to install and versatile, for upholstery

with a more futuristic design than those with more minimal shapes. Equipped with a sliding movement, the transition from a closed position to a chaise longue position takes place manually, bringing the seat forward by a good 36.5 cm

Optional

ACCESSORIES

HEADREST

Motionitalia Design and quality Made in Italy

Headquarters: via Navicella 26, 47122 Forlì (FC) Tel. +39 0543 77 47 68 Fax. +39 0543 79 84 09 www.motionitalia.com info@motionitalia.com

The producer reserves the right to modify, at any moment and without notice, the technical specification of its products

SLIDING SITTING *motorized*

Code PE08034-XXX



DESIGN IN MOVIMENTO

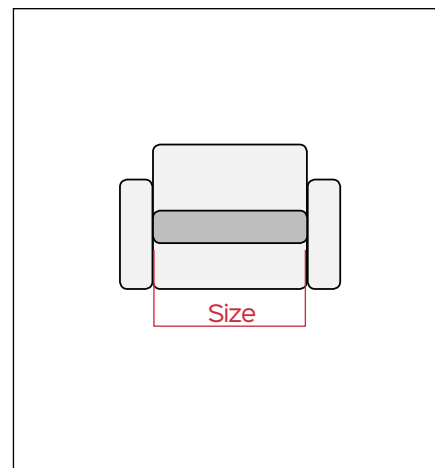

Standard sizes
450
550
650
750

Motorized	14,5 kg +/- 1kg	0-Wall	Armchairs	Sofas	Load:100kg	Cycles:30.000	2 YEARS Mechanism 2 YEARS Actuator Warranty
-----------	-----------------	--------	-----------	-------	------------	---------------	---

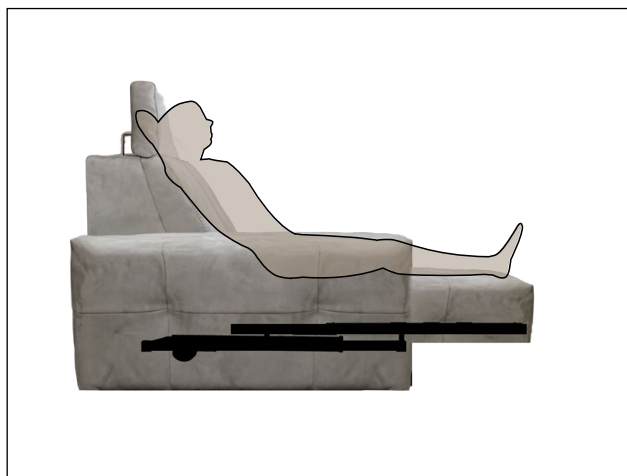

Positions:



Closed



Full Relax

Benefit: The sliding sitting mechanism motorized is simple that fits to the frame of the sofa, it's made to high quality material to avoid wear over time. The structure of the mechanism is light but functional, easy to install and versatile, for upholstery with a

more futuristic design than those with more minimal shapes. Equipped with a sliding movement, the transition from a closed position to a chaise longue position by activating an actuator that slides the seat forward by 36.5 cm.

Optional

ACCESSORIES
HEADREST

ELECTRIC KIT	
	ACTUATORS
PLUGS & CABLE EXTENSIONS	POWER SUPPLY & BATTERY PACKS

CONTROL SYSTEMS		
	BUILT IN SWITCHES	CONTROL PLATES
TOUCH SENSOR	REMOTES	IPAD/IPOD CONTROL SYSTEM

Motionitalia Design and quality Made in Italy

Headquarters: via Navicella 26, 47122 Forlì (FC) Tel.+39 0543 77 47 68 Fax.+39 0543 79 84 09 www.motionitalia.com info@motionitalia.com

The producer reserves the right to modify, at any moment and without notice, the technical specification of its products

SLIDING SITTING only elastic belt

manual Code MOCLMA07420-XXX



DESIGN IN MOVIMENTO

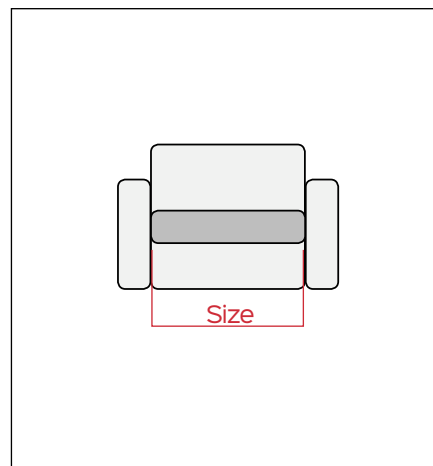
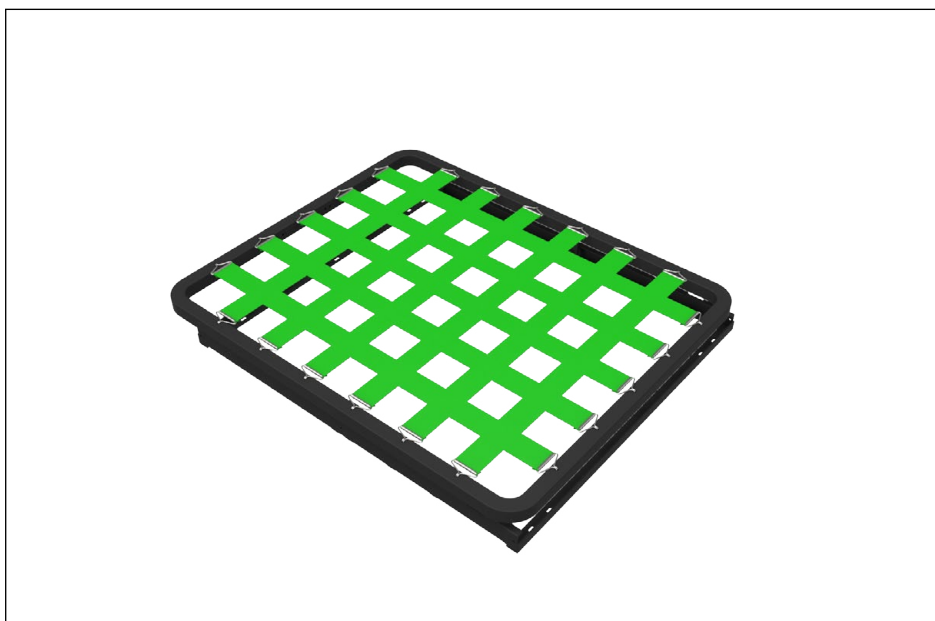

Standard sizes
450
550
650
750

Manual	11,5kg +/- 1kg	0-Wall	Armchairs	Sofas	Load: 100Kg	Cycles: 50.000	2YEARS Warranty
--------	----------------	--------	-----------	-------	-------------	----------------	-----------------

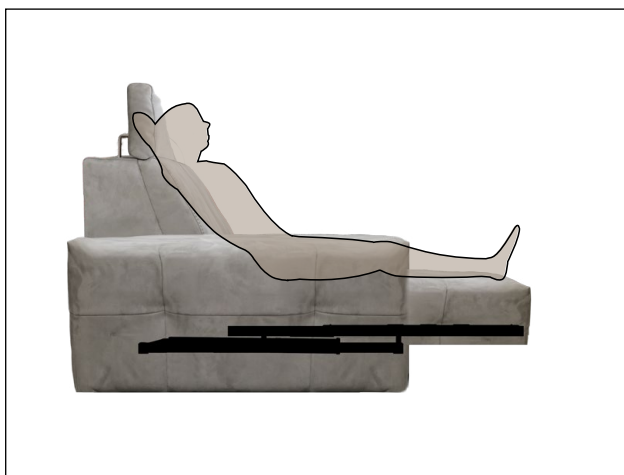

Positions:

Closed

Full Relax

Benefit: The sliding sitting only elastic belt manual is simple that fits to the frame of the sofa, it's made to high quality material to avoid wear over time. The structure of the mechanism is light but functional, easy to install and versatile, for upholstery

with a more futuristic design than those with more minimal shapes. Equipped with a sliding movement, the transition from a closed position to a chaise longue position takes place manually, bringing the seat forward by a good 36.5 cm

Optional

ACCESSORIES

HEADREST

Motionitalia Design and quality Made in Italy

Headquarters: via Navicella 26, 47122 Forlì (FC) Tel. +39 0543 77 47 68 Fax. +39 0543 79 84 09 www.motionitalia.com info@motionitalia.com

The producer reserves the right to modify, at any moment and without notice, the technical specification of its products

SLIDING SITTING only elastic belt

motorized Code PE07420-XXX



DESIGN IN MOVIMENTO

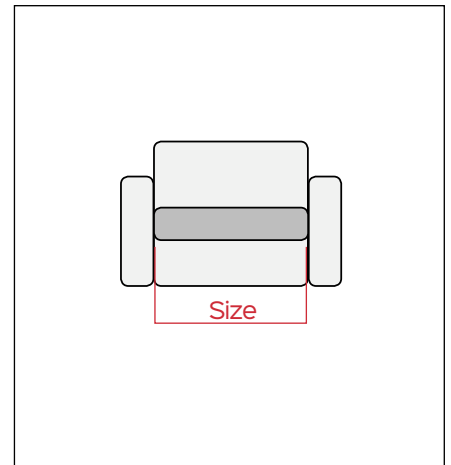
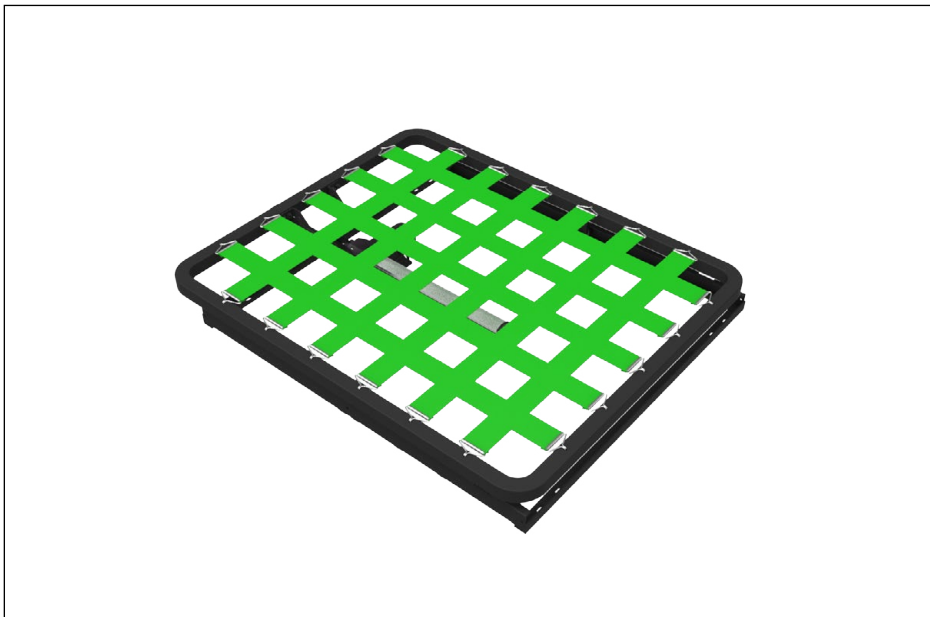

Standard sizes
450
550
650
750

Motorized	13,5 kg±1kg	0-Wall	Armchairs	Sofas	Load:100kg	Cycles:30.000	2YEARS Mechanism 2YEARS Actuator Warranty
-----------	-------------	--------	-----------	-------	------------	---------------	---

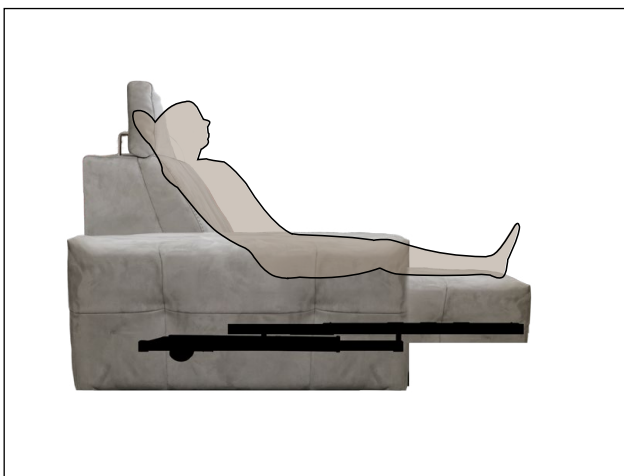

Positions:

Closed	Full Relax

Benefit: The Sliding sitting only elastic belt mechanism motorized is simple that fits to the frame of the sofa, it's made to high quality material to avoid wear over time. The structure of the mechanism is light but functional, easy to install and versatile, for

upholstery with a more futuristic design than those with more minimal shapes. Equipped with a sliding movement, the transition from a closed position to a chaise longue position by activating an actuator that slides the seat forward by 36.5 cm.

Optional

ACCESSORIES
HEADREST

ELECTRIC KIT	
	ACTUATORS
PLUGS & CABLE EXTENSIONS	POWER SUPPLY & BATTERY PACKS

CONTROL SYSTEMS		
	BUILT IN SWITCHES	CONTROL PLATES
TOUCH SENSOR	REMOTES	IPAD/IPOD CONTROL SYSTEM

Motionitalia Design and quality Made in Italy

Headquarters: via Navicella 26, 47122 Forlì (FC) Tel.+39 0543 77 47 68 Fax.+39 0543 79 84 09 www.motionitalia.com info@motionitalia.com

The producer reserves the right to modify, at any moment and without notice, the technical specification of its products

SLIDING SITTING short

manual Code MOCLMA07888-XXX



DESIGN IN MOVIMENTO

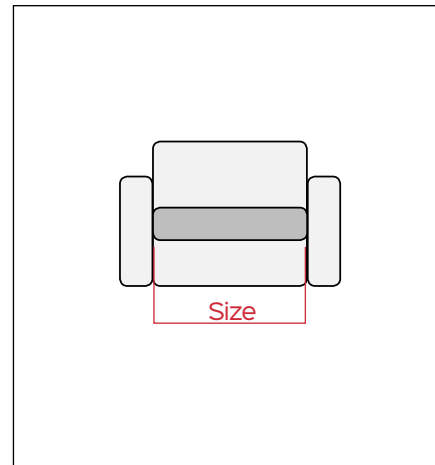
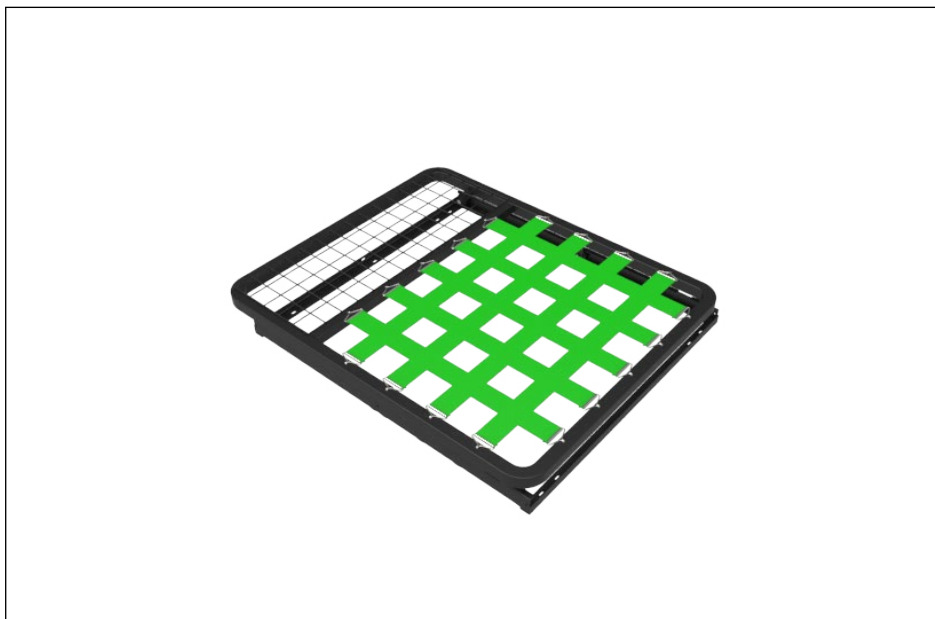

Standard sizes
450
550
650
750

Manual	12kg +/- 1kg	0-Wall	Armchairs	Sofas	Load: 100Kg	Cycles: 50.000	2YEARS Warranty
--------	--------------	--------	-----------	-------	-------------	----------------	-----------------

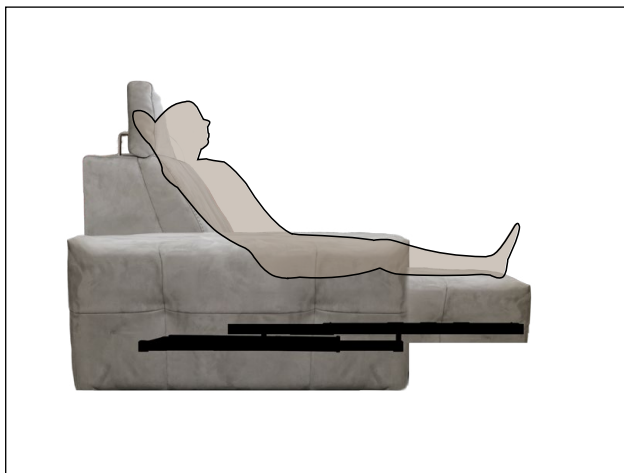

Positions:

Closed

Full Relax

Benefit: The Sliding sitting short manual mechanism manual is simple that fits to the frame of the sofa, it's made to high quality material to avoid wear over time. The structure of the mechanism is light but functional, easy to install and versatile,

for upholstery with a more futuristic design than those with more minimal shapes. Equipped with a sliding movement, the transition from a closed position to a chaise longue position takes place manually, bringing the seat forward by a good 36.5 cm

Optional

ACCESSORIES

HEADREST

Motionitalia Design and quality Made in Italy

Headquarters: via Navicella 26, 47122 Forlì (FC) Tel. +39 0543 77 47 68 Fax. +39 0543 79 84 09 www.motionitalia.com info@motionitalia.com

The producer reserves the right to modify, at any moment and without notice, the technical specification of its products

SLIDING SITTING short

motorized Code PE07888-XXX



DESIGN IN MOVIMENTO

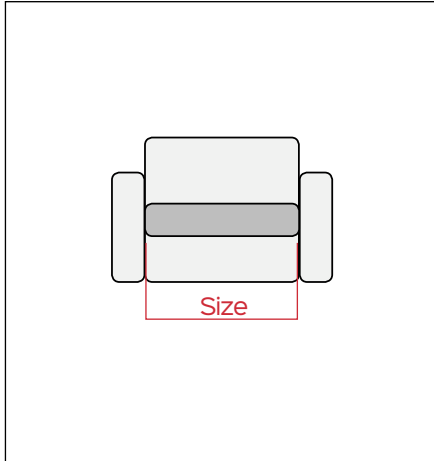
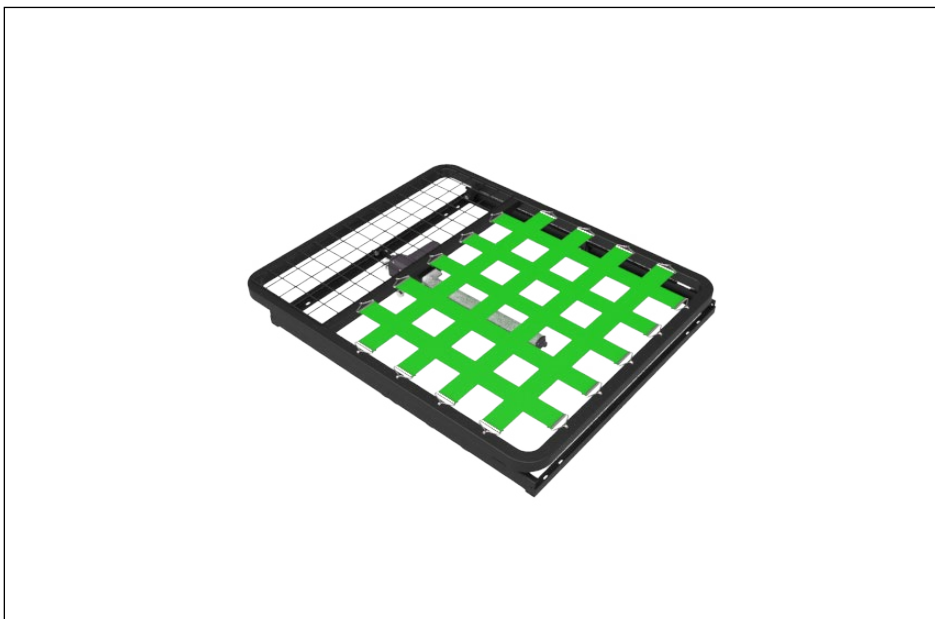

Standard sizes
450
550
650
750

Motorized	14kg±1kg	0-Wall	Armchairs	Sofas	Load:100kg	Cycles:30.000	2 YEARS Mechanism 2 YEARS Actuator Warranty
-----------	----------	--------	-----------	-------	------------	---------------	---

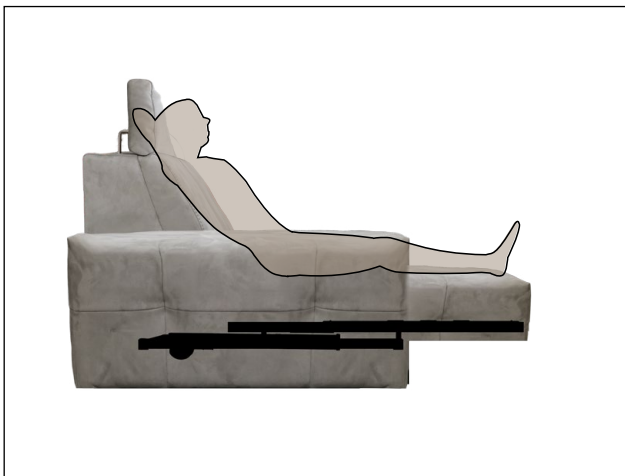

Positions:

Closed	Full Relax

Benefit: The Sliding Sitting short mechanism motorized is simple that fits to the frame of the sofa, it's made to high quality material to avoid wear over time. The structure of the mechanism is light but functional, easy to install and versatile, for upholstery

with a more futuristic design than those with more minimal shapes. Equipped with a sliding movement, the transition from a closed position to a chaise longue position by activating an actuator that slides the seat forward by 36.5 cm.

Optional

ACCESSORIES
HEADREST

ELECTRIC KIT	
	ACTUATORS
PLUGS & CABLE EXTENSIONS	POWER SUPPLY & BATTERY PACKS

CONTROL SYSTEMS		
	BUILT IN SWITCHES	CONTROL PLATES
TOUCH SENSOR	REMOTES	IPAD/IPOD CONTROL SYSTEM

Motionitalia Design and quality Made in Italy

Headquarters: via Navicella 26, 47122 Forlì (FC) Tel.+39 0543 77 47 68 Fax.+39 0543 79 84 09 www.motionitalia.com info@motionitalia.com

The producer reserves the right to modify, at any moment and without notice, the technical specification of its products