

LOINBACKREST *motorized*

Cod. PE07185-XXX



DESIGN IN MOVIMENTO



Vuoto Poggiatesta

Dash	Vuoto standard (mm)
2	474
3	499
4	524
11	702,5
14	778,5

Altre 9 misure disponibili

Elettrico	6kg +/-500gr	Poltrone	Divani	Portata: 15Kg schienale 10Kg poggiatesta	Cicli: 30.000	2 ANNI Meccanismo 2 ANNI Attuatore Garanzia
-----------	--------------	----------	--------	--	---------------	---

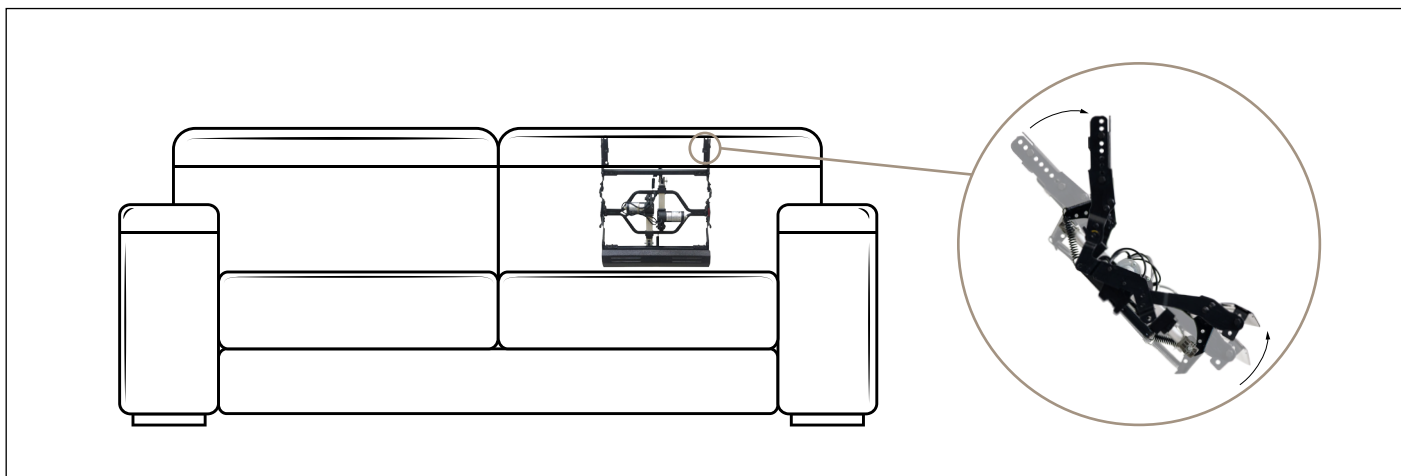

Benefit: LOINBACKREST è un prodotto ibrido che unisce la funzionalità di un poggiatesta a quella di uno schienale lombare. Compattezza, funzionalità, resistenza e versatilità sono le caratteristiche che distinguono

questo prodotto e che permettono di creare imbottiti di dimensioni ridotte senza scendere a compromessi, aprendo quindi nuovi scenari nell'ambito del furniture design.

Optional

KIT ELETTRICI	ATTUATORI
SPINE E PROLUNGHE	ALIMENTATORI E BATTERIE

SISTEMI DI CONTROLLO	INCASSO	PIASTRE
TOUCH SENSOR	TELECOMANDI	CONTROLLO IPAD/IPOD

Motionitalia Design and quality Made in Italy

Headquarters: via Navicella 26, 47122 Forlì (FC) Tel. +39 0543 77 47 68 Fax. +39 0543 79 84 09 www.motionitalia.com info@motionitalia.com

Il produttore si riserva il diritto di modificare, in qualsiasi momento e senza preavviso, le specifiche tecniche dei propri prodotti

LOINBACKREST *motorized*

Code PE07185-XXX

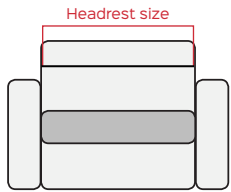

DESIGN IN MOVIMENTO

Dash	Standard size (mm)
2	474
3	499
4	524
11	702,5
14	778,5

9 other measures available

Motorized	6kg +/-500gr	Armchairs	Sofas	Load: 15kg backrest 10kg headrest	Cycles:30.000	2YEARS Mechanism 2YEARS Actuator Warranty
-----------	--------------	-----------	-------	-----------------------------------	---------------	---

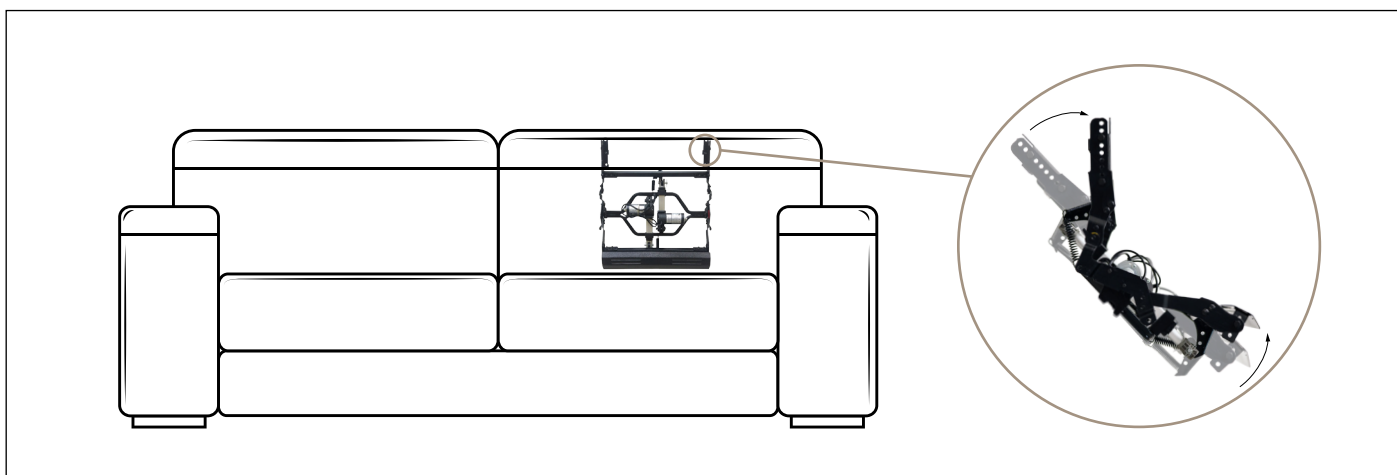

Benefit: LOINBACKREST is a hybrid product, combining the functionality of a headrest with the one of the lumbar backrest. Characterized by compactness, functionality, strength and versatility,

allows to create upholstered furniture with reduced dimension without compromising, opening new scenarios in the field of furniture design.

Optional

ELECTRIC KIT	ACTUATORS
PLUGS & CABLE EXTENSIONS	POWER SUPPLY & BATTERY PACKS

CONTROL SYSTEM	BUILT IN SWITCHES	CONTROL PLATES
TOUCH SENSOR	REMOTES	IPAD/IPOD CONTROL SYSTEM

Motionitalia Design and quality Made in Italy

Headquarters: via Navicella 26, 47122 Forlì (FC) Tel.+39 0543 77 47 68 Fax.+39 0543 79 84 09 www.motionitalia.com info@motionitalia.com

The producer reserves the right to modify, at any moment and without notice, the technical specification of its products