

GO UP^{plus motorized}

Cod. PE06500-XXX

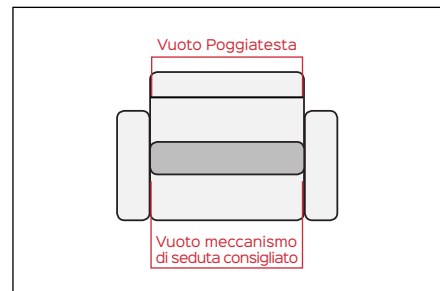

DESIGN IN MOVIMENTO



Vuoto standard (mm)	
Vuoto Meccanismo di seduta consigliato	Vuoto Poggiatesta
540	370
650	480
730	560
800	630
880	710

Oltre 30 misure disponibili

Elettrico	5kg +/- 500gr	106°-222°	Poltrone	Divani	Portata: 15kg	Cicli: 30.000	2 ANNI Meccanismo 2 ANNI Attuatore Garanzia
-----------	---------------	-----------	----------	--------	---------------	---------------	---

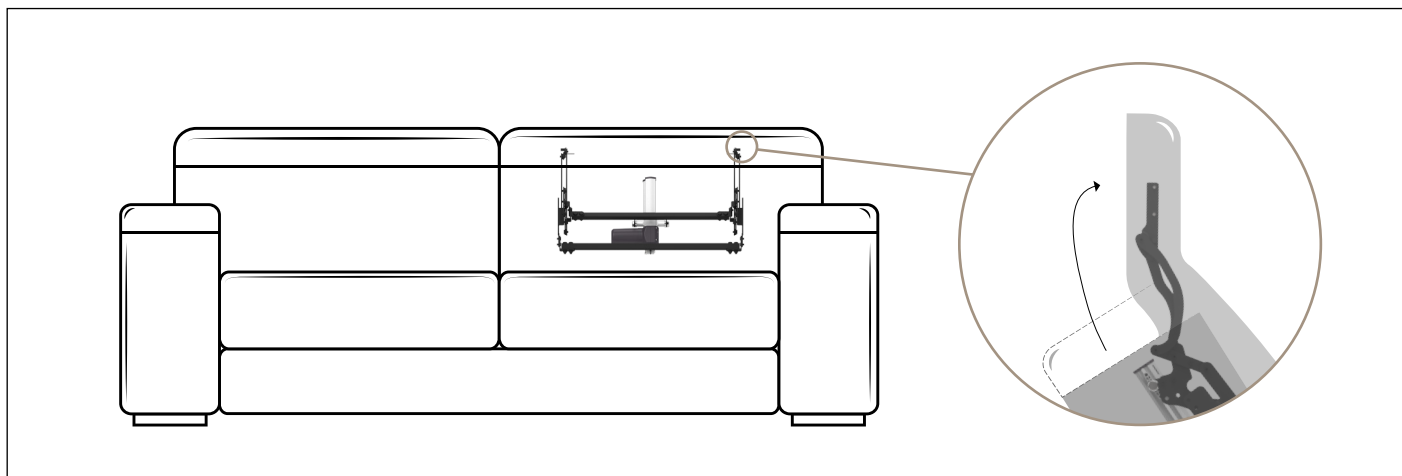

Benefit: Alta efficienza e qualità nell'uso dei materiali e delle componenti elettriche. Ingombri ridotti e versatilità nell'utilizzo (rotazione di 115°, alzata 192mm, traslazione 147mm). Alta efficienza del comfort

in tutte le posizioni, dalla Tv alla relax, in quest'ultima posizione il supporto cervicale permette all'utente di mantenere una corretta postura e di usufruire del prodotto in completa comodità.

Optional

ACCESSORI

FINITURE

KIT ELETTRICI

ATTUATORI

SPINE E PROLUNGHE

ALIMENTATORI E BATTERIE

SISTEMI DI CONTROLLO

INCASSO

PIASTRE

TOUCH SENSOR

TELECOMANDI

CONTROLLO IPAD/IPOD

Motionitalia Design and quality Made in Italy

Headquarters: via Navicella 26, 47122 Forlì (FC) Tel. +39 0543 77 47 68 Fax. +39 0543 79 84 09 www.motionitalia.com info@motionitalia.com

Il produttore si riserva il diritto di modificare, in qualsiasi momento e senza preavviso, le specifiche tecniche dei propri prodotti

GO UP^{plus} motorized

Code PE06500-XXX



DESIGN IN MOVIMENTO

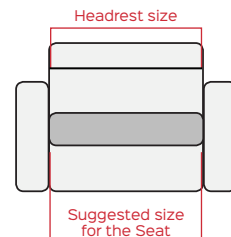

Standard sizes (mm)

Suggested size for the Seat	Headrest size
540	370
650	480
730	560
800	630
880	710

More than 30 measures available

Motorized	5kg +/- 500gr	106°-222°	Armchairs	Sofas	Load:15kg	Cycles:30.000	2YEARS Mechanism 2YEARS Actuator Warranty
-----------	---------------	-----------	-----------	-------	-----------	---------------	---

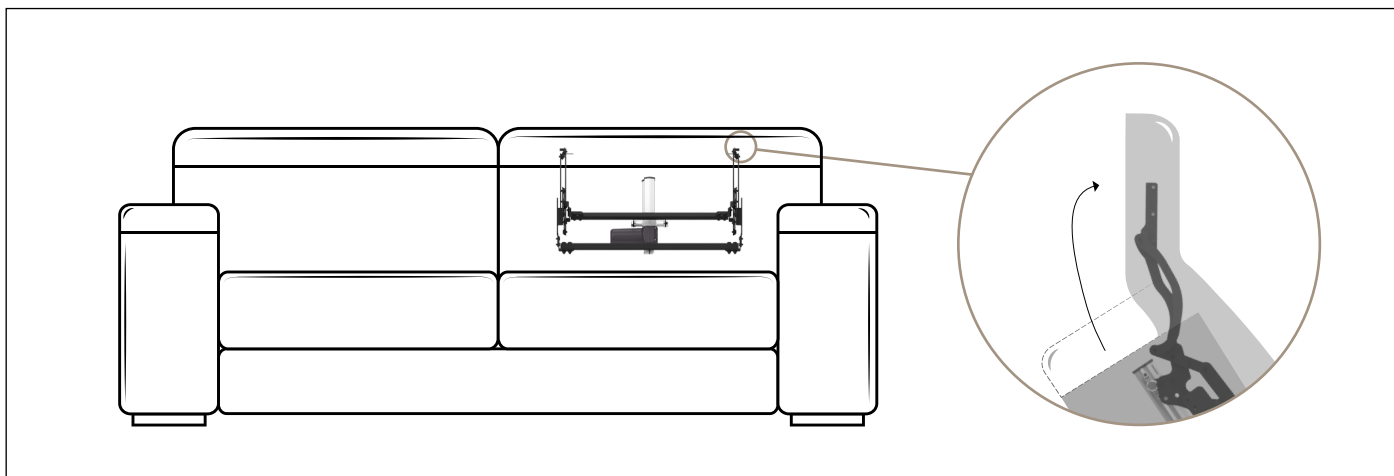

Benefit: Highgrade and efficiency materials and electric components. Narrow shape and great versatility (115° rotation, rise 192mm, shift 147mm). High comfort efficiency in every position, from Tv to relax. While in

relax position, the cervical support provides a correct posture and full comfort.

Optional

ACCESSORIES

FINISHES

ELECTRIC KIT

ACTUATORS

PLUGS & CABLE EXTENSIONS

POWER SUPPLY & BATTERY PACKS

CONTROL SYSTEM

BUILT IN SWITCHES

CONTROL PLATES

TOUCH SENSOR

REMOTES

IPAD/IPOD CONTROL SYSTEM

Motionitalia Design and quality Made in Italy

Headquarters: via Navicella 26, 47122 Forlì (FC) Tel.+39 0543 77 47 68 Fax.+39 0543 79 84 09 www.motionitalia.com info@motionitalia.com

The producer reserves the right to modify, at any moment and without notice, the technical specification of its products